

# Status relations in school and their relevance for health in a life-course perspective

Viveca Östberg and Bitte Modin  
Centre for Health Equity Studies, CHES  
Stockholm University/Karolinska Institutet



## Study questions

- Is children's status position in school (peer status) linked to their health in mid-life?
- If so – how is the association produced?

Aberdeen, 1964, 8-12 year old children  
50 schools, 524 school classes, 13945 children



Peer Status

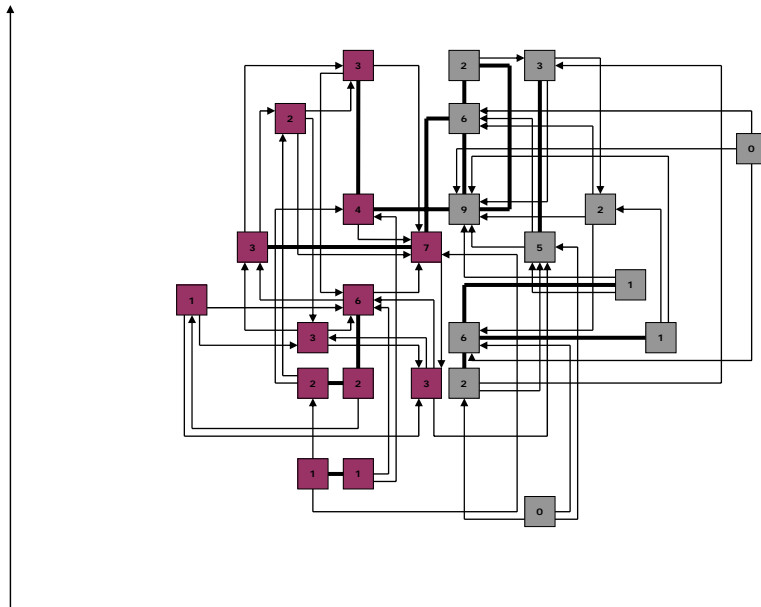

### Frequency distribution of number of choices

Children 8-12 years, Aberdeen 1964  
13945 children, 524 school classes

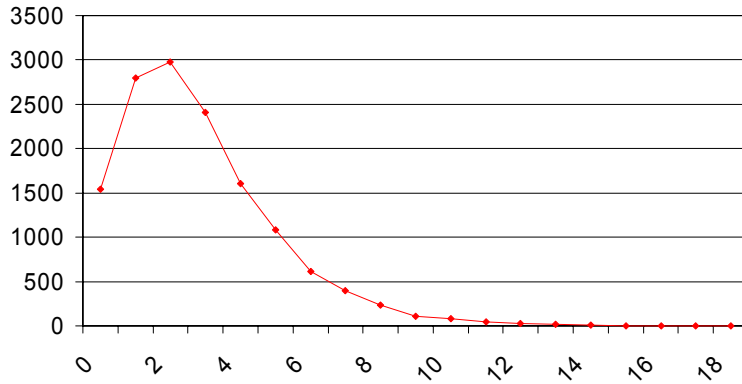

### Peer status in the school class (%)

Children 8-12 years, Aberdeen 1964, n=13945

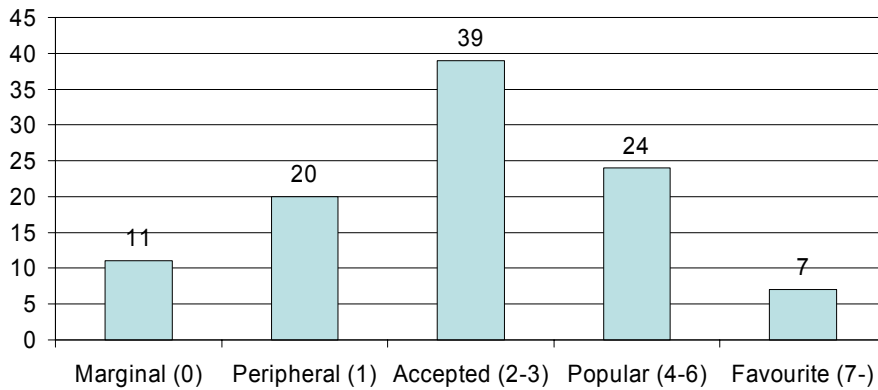

## Peer status in the school class (%)

Children 8-12 years, Aberdeen 1964, n=13945

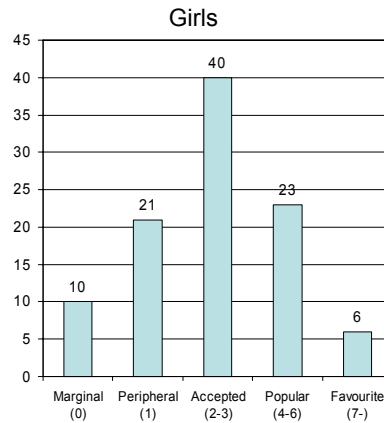
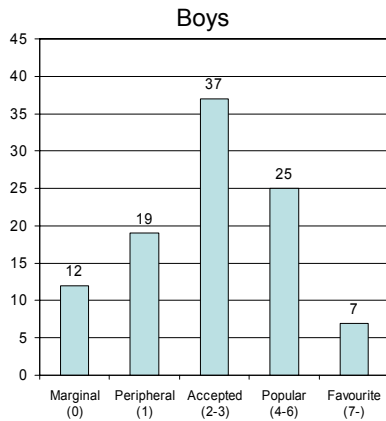

## Peer status in the school class (%)

Children 8-12 years, Aberdeen 1964, n=13945

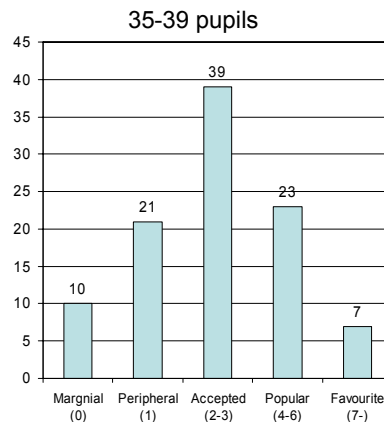
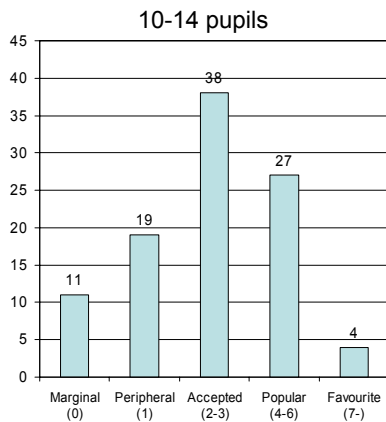

# Peer status in the school class (%)

Children 8-12 years, Aberdeen 1964, n=13945

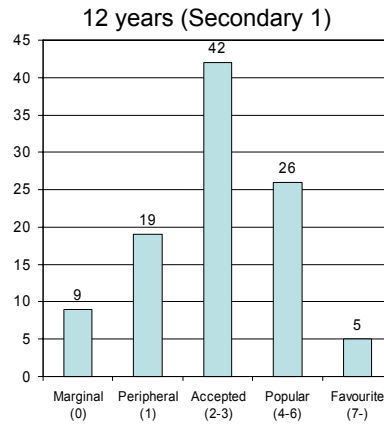
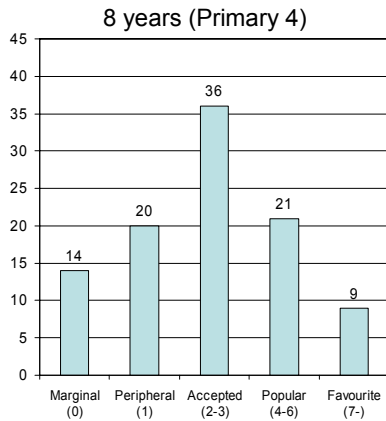

Hypothetical model of the association between peer status and health determinants in a life-course perspective

